

Los contenedores de la serie OPENBOX están fabricados en polipropileno de primera calidad. Gracias a su estructura con abertura frontal de doble pared, mantienen el contenido siempre a la vista y permiten un apilado estable y seguro incluso a plena carga. Poseen una alta resistencia química a aceites y grasas, así como a los cambios de temperatura.

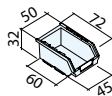

GAMA DE COLORES:



Art. PL0151 (OP-01)
Dim. 72/60x45x32h mm
Cap. 0,08 litros

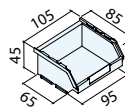

Art. PL0951 (OP-0)
Dim. 85/65x95x45h mm
Cap. 0,25 litros

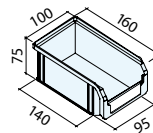

Art. PM1751 (OP-1)
Dim. 160/140x95x75h mm
Cap. 1 litros

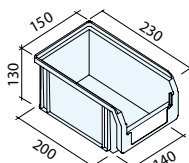

Art. PM2551 (OP-2)
Dim. 230/200x140x130h mm
Cap. 3,8 litros

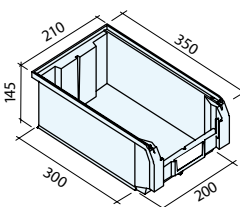

Art. PM3351 (OP-3A2)
Dim. 350/300x200x145h mm
Cap. 9,4 litros

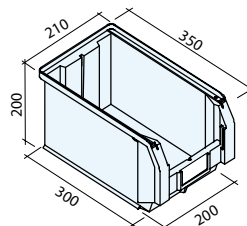

Art. PM4151 (OP-3)
Dim. 350/300x200x200h mm
Cap. 12,5 litros

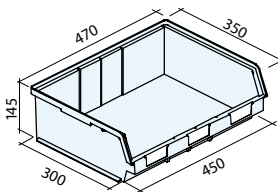

Art. PL4951 (OP-3L5)
Dim. 350/300x450x145h mm
Cap. 19 litros

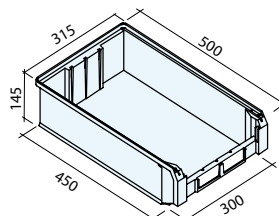

Art. PM5751 (OP-4A2)
Dim. 500/450x300x145h mm
Cap. 20 litros

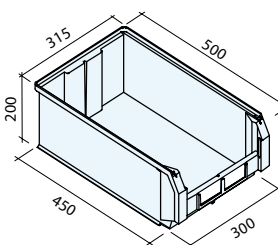

Art. PM6551 (OP-4)
Dim. 500/450x300x200h mm
Cap. 28 litros

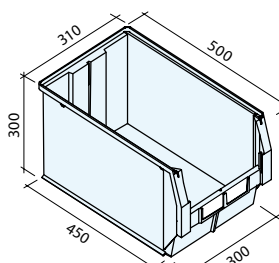

Art. PM7351 (OP-4A5)
Dim. 500/450x300x300h mm
Cap. 42 litros

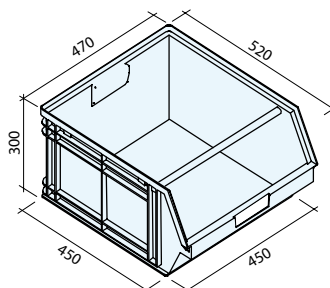

Art. PL8151 (OP-5P4Z)
(con travesaño)
Dim. 520/450x450x300h mm
Cap. 63 litros

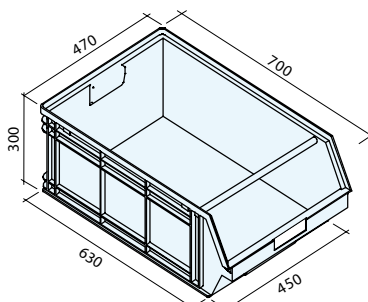

Art. PL8951 (OP-5Z)
(con travesaño)
Dim. 700/630x450x300h mm
Cap. 88 litros

